

























































Q.6(c) In detail, with neat sketch explain the control unit section of mobile phone unit. [8]

(A) Control Unit Section

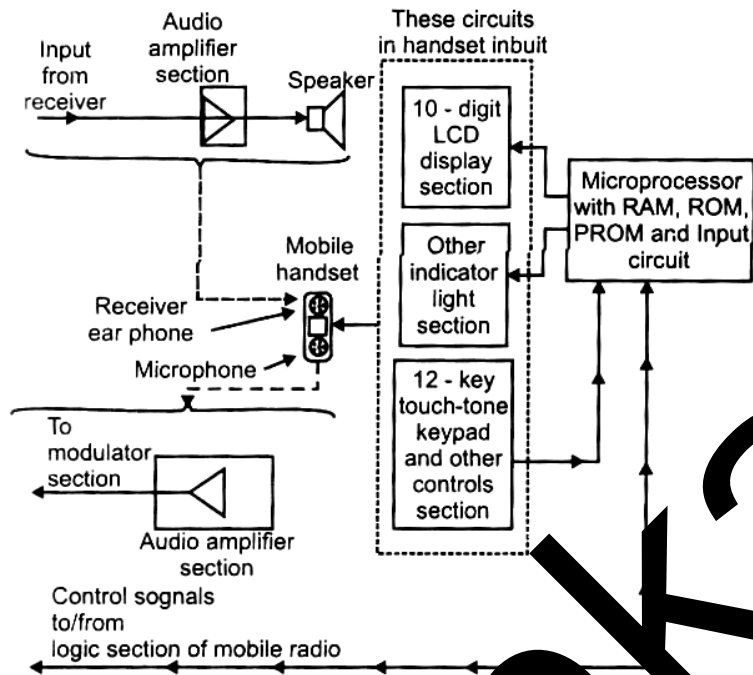

Fig.: Control Unit With Handset of Mobile/Cellular Radio

- (i) The control unit with handset is as shown in figure.
- (ii) The part of control sections are :
  - (a) Handset with speaker and microphone.
- (iii) Also the main control section unit contains such as dialing circuit.
- (iv) The control unit is operated by a separate microprocessor section that drives the indicators and LCD display section.
- (v) Manual control functions are also implemented here.
- (vi) The memory of microprocessor also permits the storage of numbers oftenly used and also the auto-dial feature.

□□□□□